

Model-DW50 EW50 IW50 PW50 RW50 VW50

OFFICE BED WITH HUTCH INSTALLATION GUIDE

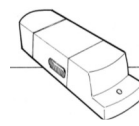
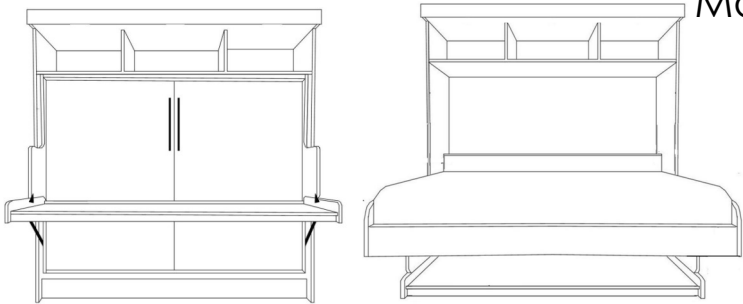

PHILLIPS SCREWDRIVER CORDLESS DRILL STUD FINDER 6' LADDER
ITEMS NEEDED TO ASSEMBLE YOUR BED

HARDWARE (not to scale)

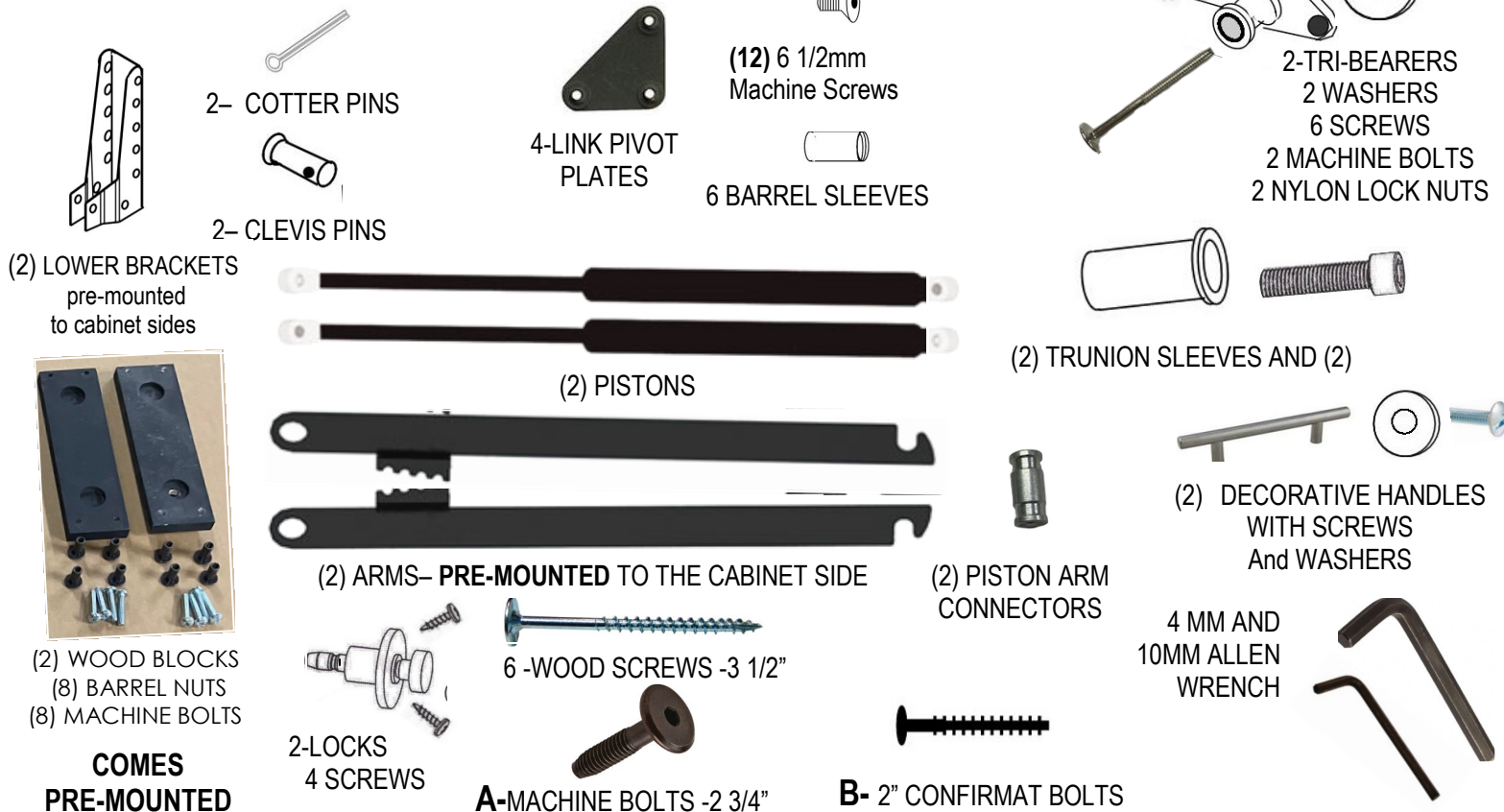

1 CABINET ASSEMBLY

The cabinet side comes with the lever arm already attached.

Connect loose end of piston to lower bracket at bottom with Clevis pin and Cotter Pin provided.

Secure the cotter pin by bending ends.

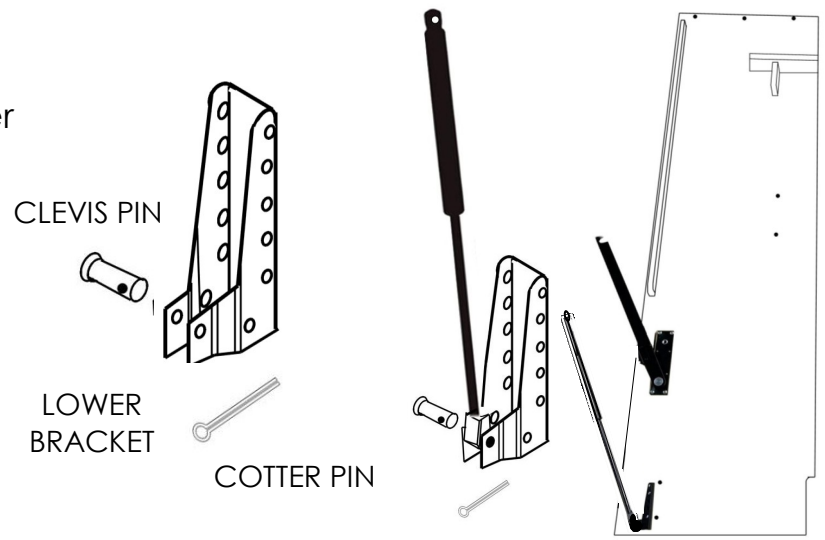

WARNING! ALL PISTONS CONTAIN STORED ENERGY. FAILURE TO FOLLOW THESE INSTRUCTIONS COULD RESULT IN DAMAGE TO THE PRODUCT, PERSONAL INJURY OR DEATH.. PLEASE CALL 916-607-7728 WITH ANY QUESTIONS.

2 ATTACH THE TOP TO THE SIDES using the MACHINE bolts **(A)**

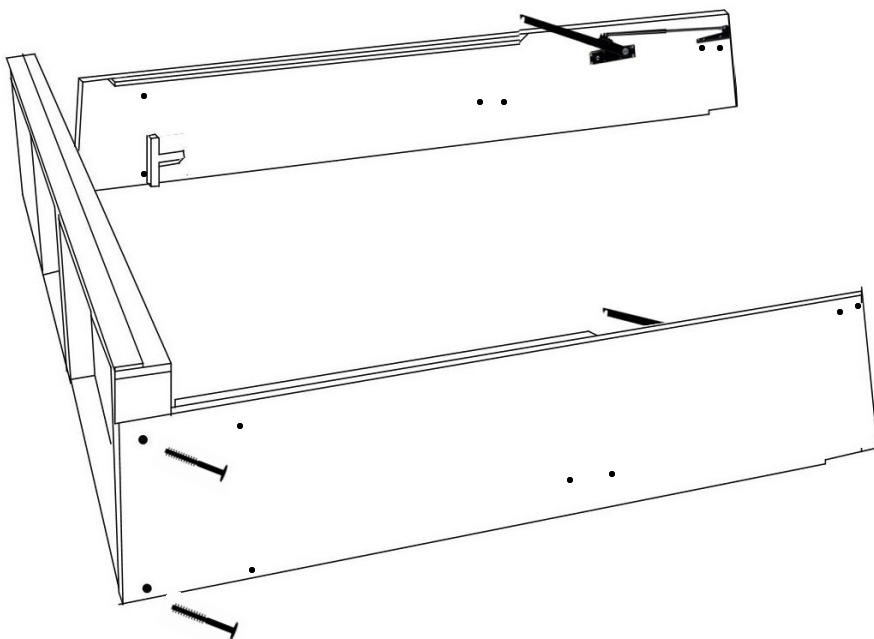

3 ATTACH THE SHELF HEADBOARD TO THE SIDES using the CONFIRMAT bolts **(B)**

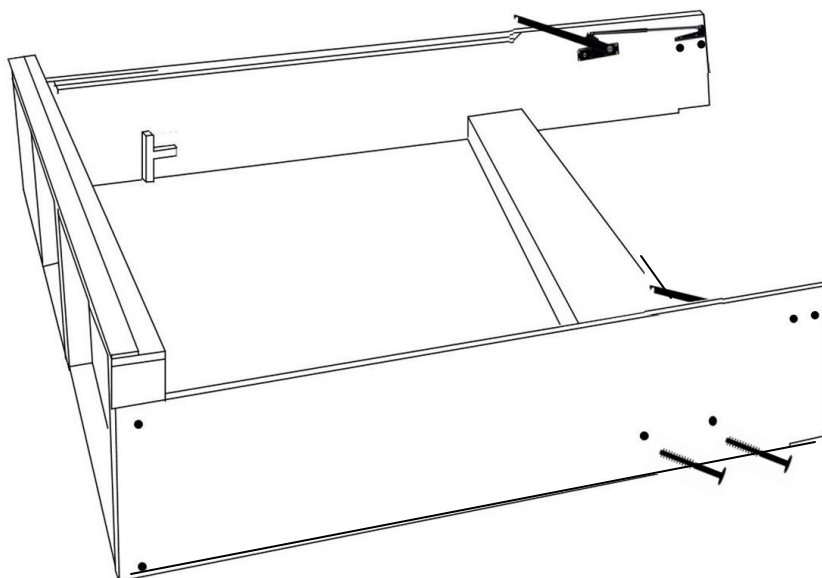

4 ATTACH HUTCH SHELF
Insert hutch shelf between the cabinet sides and attach with confirmat bolts **(B)** keeping finished edges to

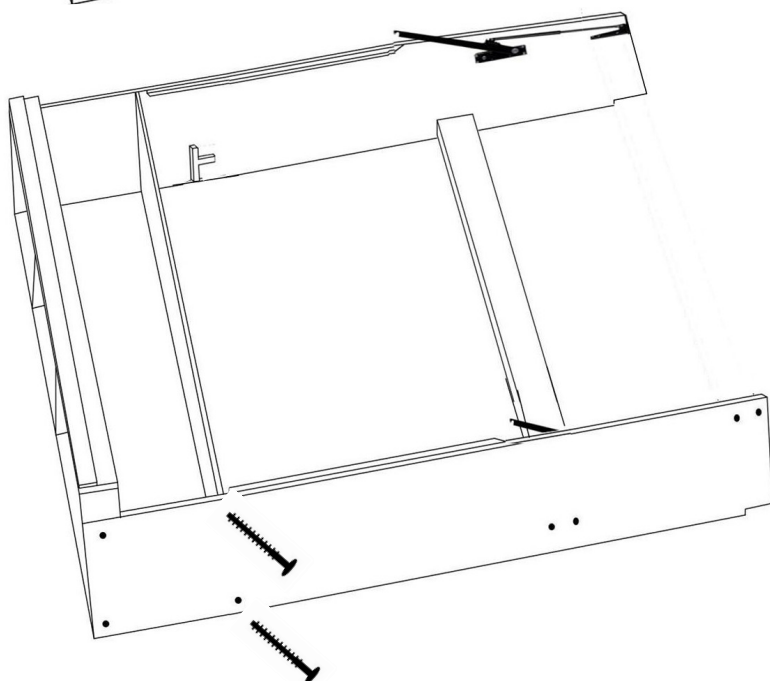

- 5** ATTACH LOWER STRONGBACK
Insert lower strongback
between the cabinet sides and
attach with confirmat bolts **(B)**
keeping finished edges to front.

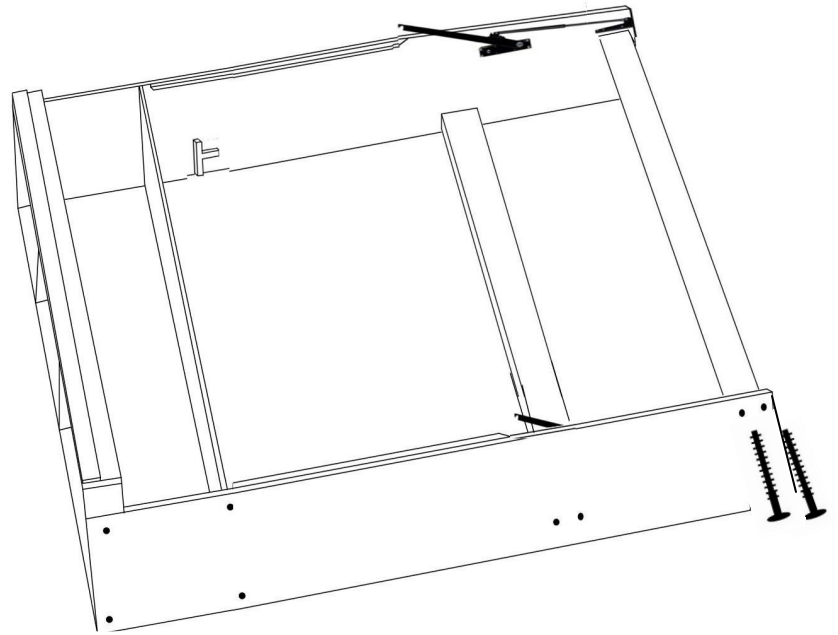

- 6** INSTALL SHELF UPRIGHTS Insert hutch
shelf uprights between the shelf
and the cabinet top crown as-
sembly using confirmat bolts **(B)**.
Shelf holes towards the sides.
Adjust the top crown as-
sembly position so that the top crown as-
sembly is level and straight. The
top crown assembly alignment
will be determined by the parti-
tions fixed to the top crown as-
sembly.

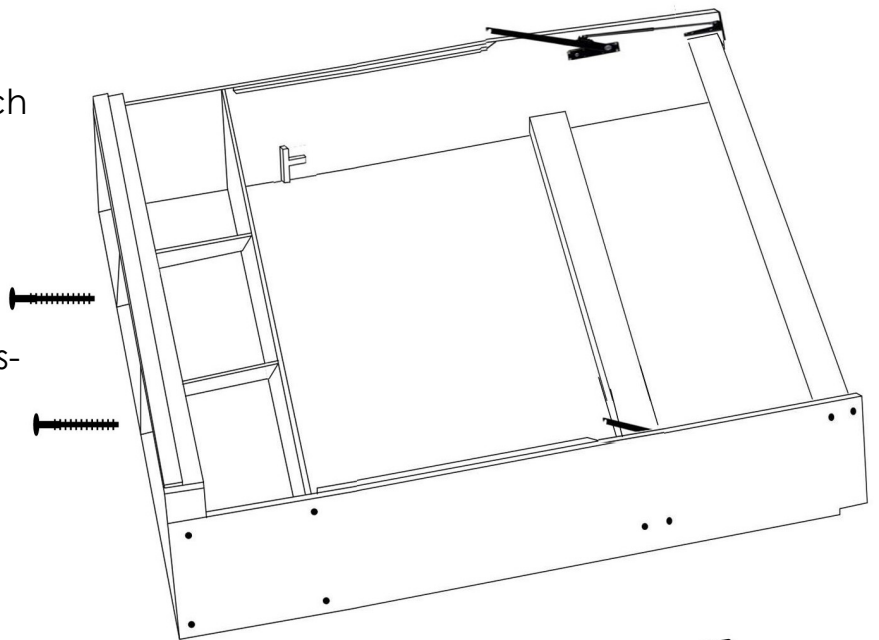

- 7** STAND UP ASSEMBLED CABINET AGAINST WALL

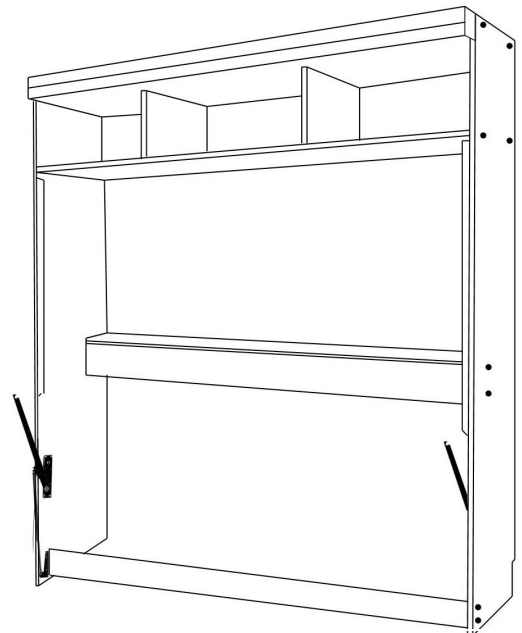

8

ATTACH CABINET TO WALL Be sure that the cabinet is perfectly square on the wall. Use the (6) 3/12" wood screws to attach the cabinet into 3 wood studs in the wall through the back of the top.



6 -WOOD SCREWS -3 1/2"

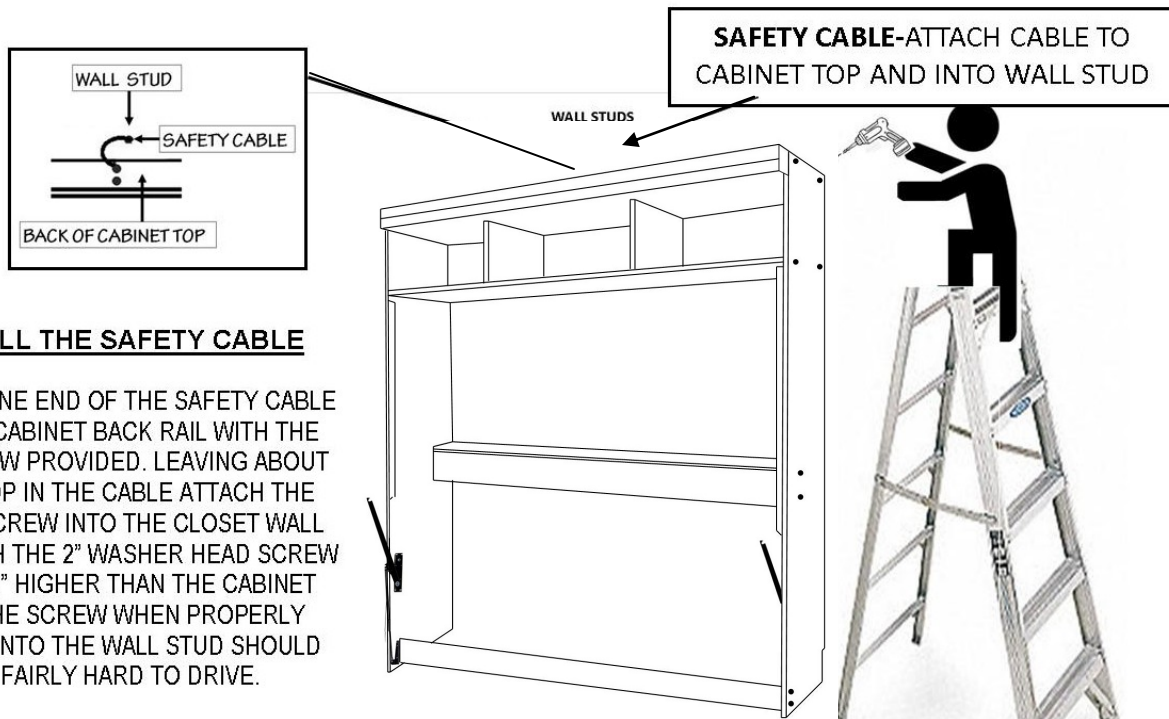

INSTALL THE SAFETY CABLE

ATTACH ONE END OF THE SAFETY CABLE TO THE CABINET BACK RAIL WITH THE 3/4" SCREW PROVIDED. LEAVING ABOUT A 3" LOOP IN THE CABLE ATTACH THE WOOD SCREW INTO THE CLOSET WALL STUD WITH THE 2" WASHER HEAD SCREW ABOUT 1" HIGHER THAN THE CABINET TOP. THE SCREW WHEN PROPERLY DRIVEN INTO THE WALL STUD SHOULD BE FAIRLY HARD TO DRIVE.

THE FUNCTION OF THE SAFETY CABLE IS TO MAKE ATTACHMENT FAILURE OF THE BED VISABLE BY ALLOWING THE BED TO COME AWAY FROM THE WALL 2 TO 3 INCHES. WHEN YOU SEE THIS CONDITION **DO NOT OPEN THE BED!** YOU MUST INVESTIGATE WHAT IS WRONG AND CORRECT IT!

TRAY ASSEMBLY

9

The tray ends are not universal. There is a left and right side. The sides come with the red nylon inserts pre installed. **IT IS CRITICAL** that the thicker part of the insert is facing inwards towards the center of the tray. ATTACH the tray ends with (B) 2" confirmat bolts as shown.

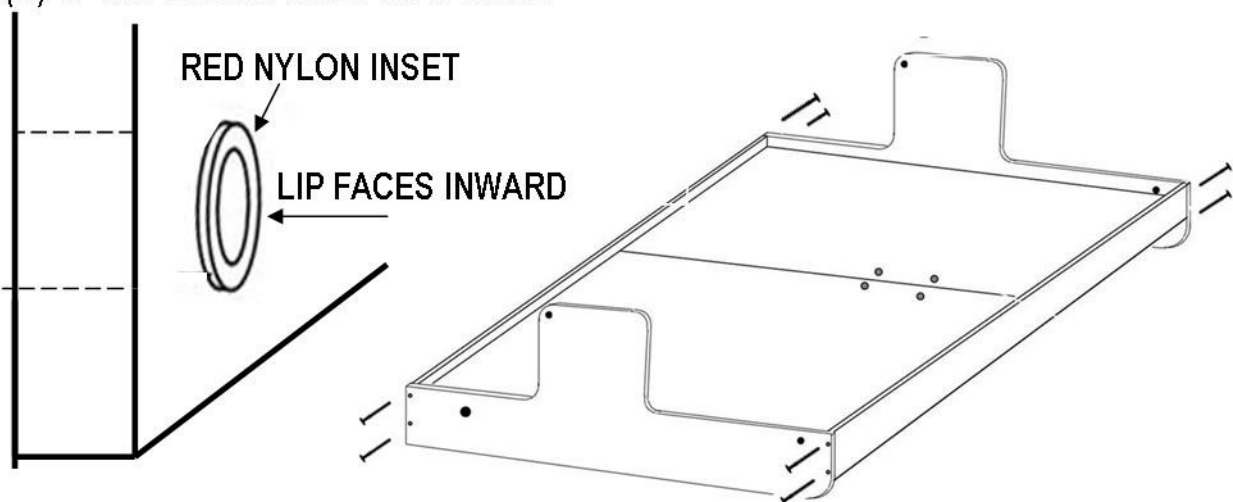

10 ATTACH DESK TO TRAY Place desk vertically on the mattress tray and attach with link pivot plates using barrel and 6 1/2mm machine screws to plate. Insert in holes, attach remaining screws, then tighten all.

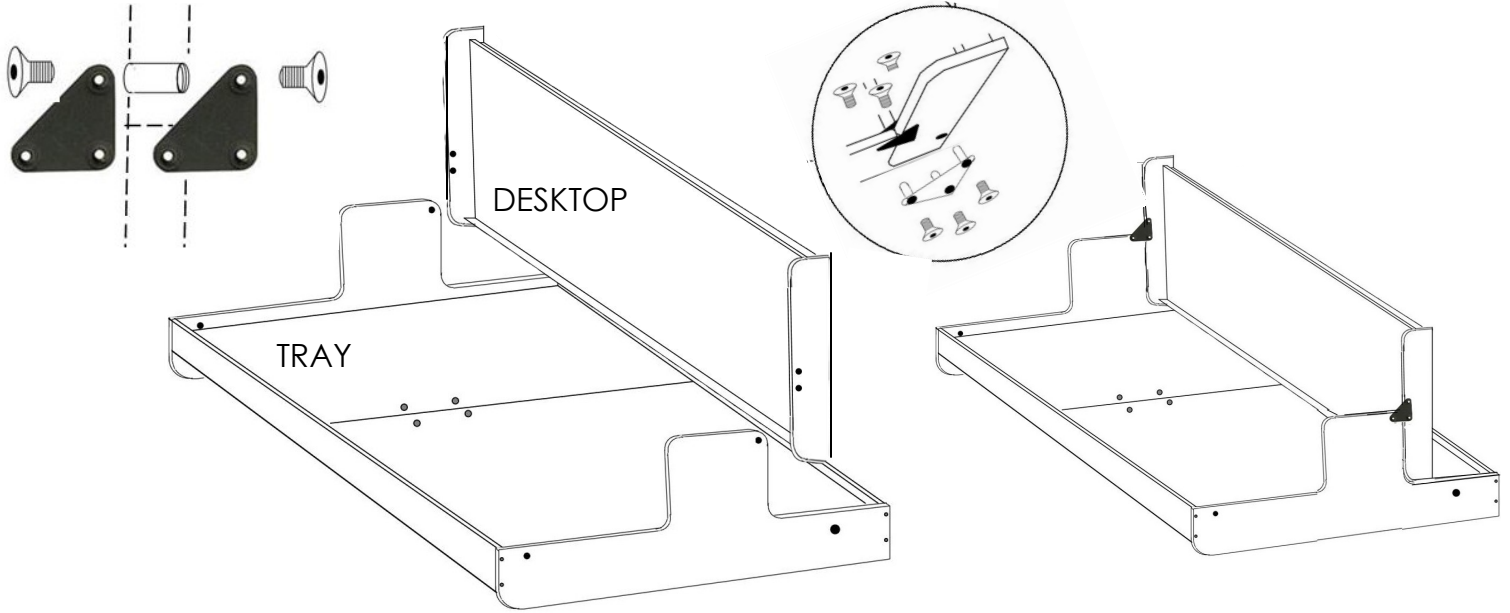

11 FOLD DOWN DESK Fold desk horizontally over the finished bottom of the mattress tray.

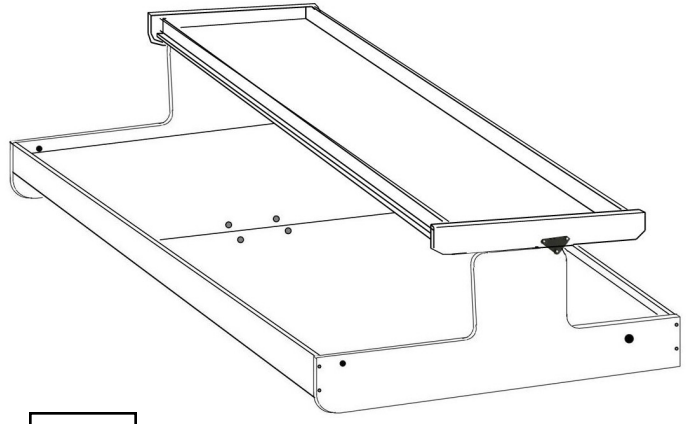

12 Attach bearer assembly At each desk end, bolt bearer through wood through the washer into the nylon lock nut. Tighten firmly, but leave enough slack to slightly adjust the position later.
DO NOT APPLY SCREWS INTO HOLES ON THE FLANGE NOW

13 INSTALL LOCKS Attach black locking assembly to the inside on the bed end panels in holes provided, using screw. Retract the pins for assembly clearance.

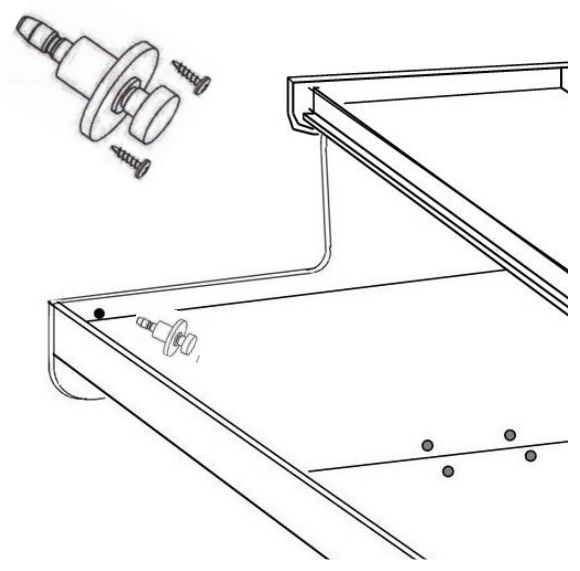
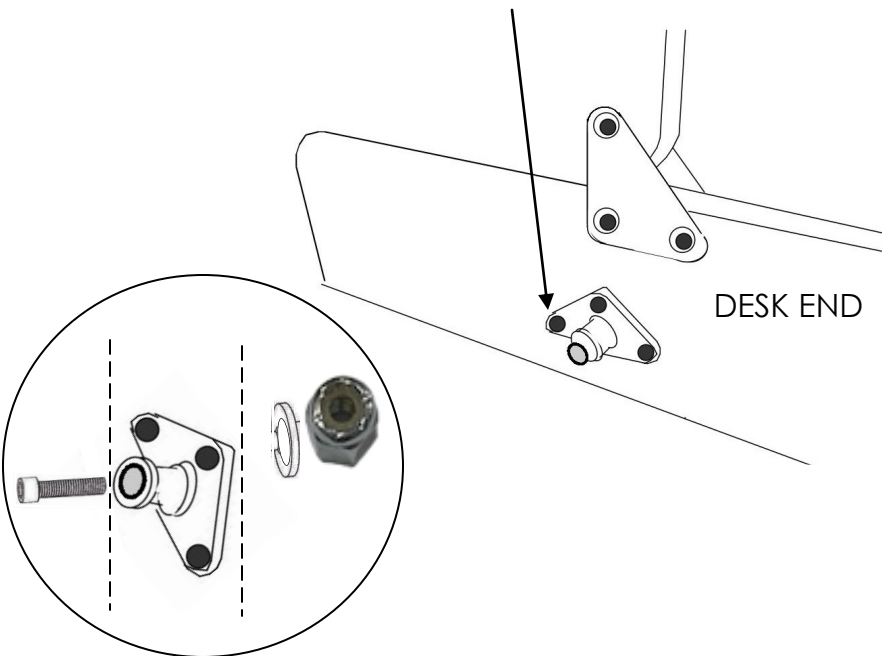

13 POSITION DESK TRAY- Roll the entire assembly over so the desk bottom is on the floor and the mattress bed tray is facing up. Desk should be resting on the floor. Finished edge facing into the room.

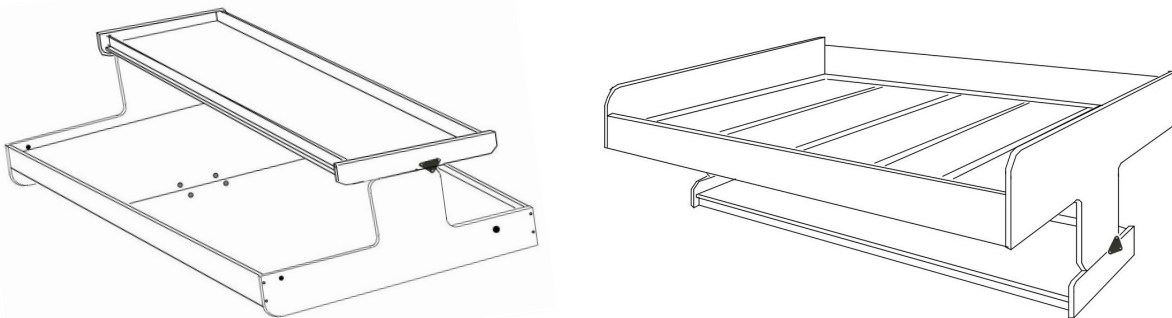

14 ATTACHING DESK WITH TRAY INTO CABINET Slide the DESK/TRAY into the standing cabinet.

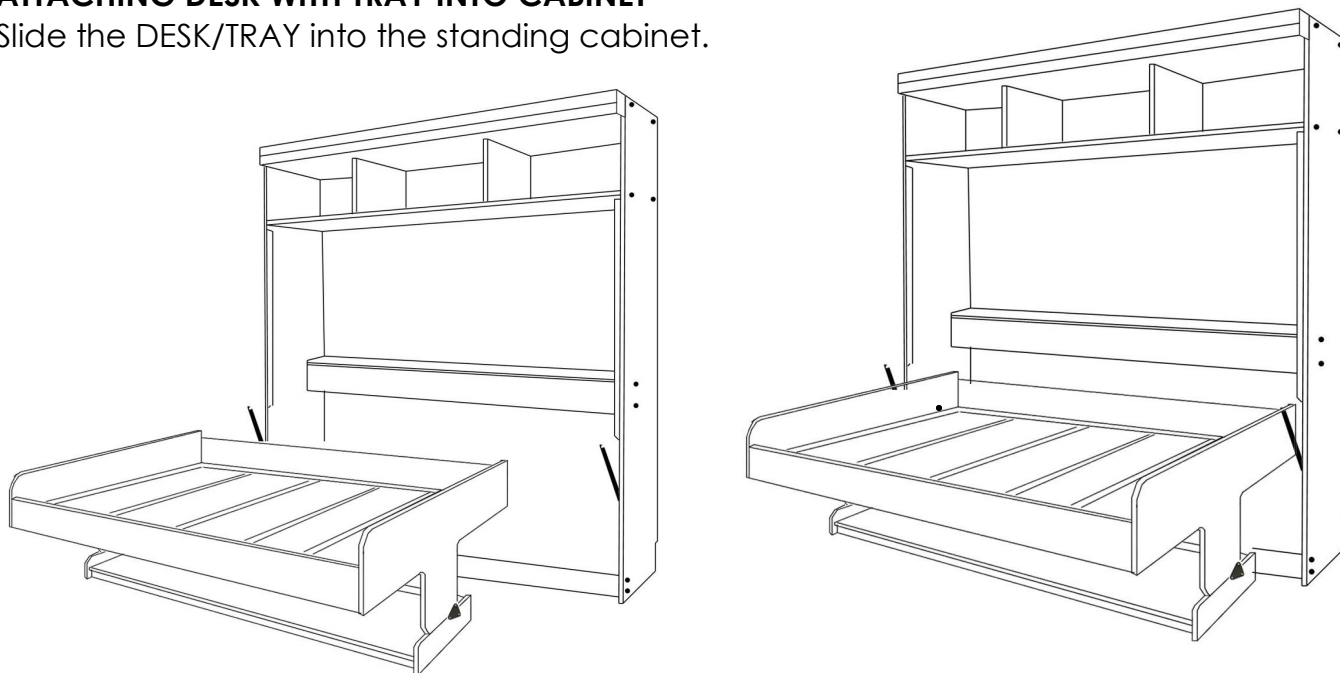

15 INSERT TRUNION BOLT Line up the trunion hole in the bed tray with the connecting threaded hole at the upper end of the lever arm bracket mounted to the cabinet side panel. From behind the unit, slide the trunion sleeve and bolt through the hole in the lever arm bracket. Once both trunions are in place, use the 10mm allen wrench to firmly tighten the trunion bolts.

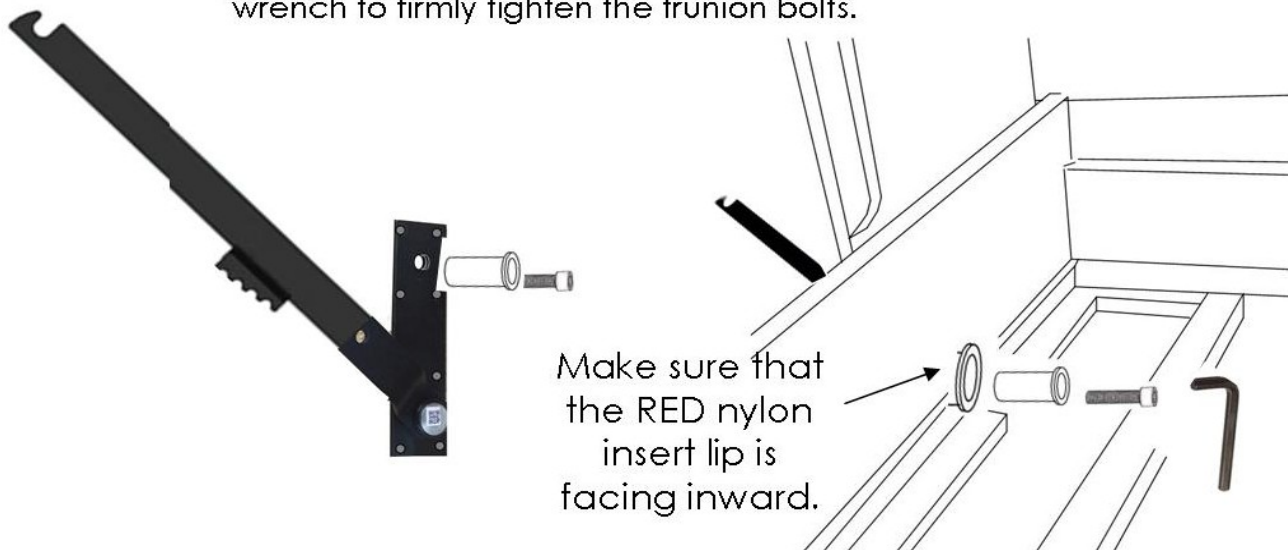

16**CONNECT THE PISTON TO THE ARM**

Raise and LOCK the bed in the UP or CLOSED position. . Insert the barrel piston arm connector into the hole at the piston end. Insert the piston into the second valley as shown here.

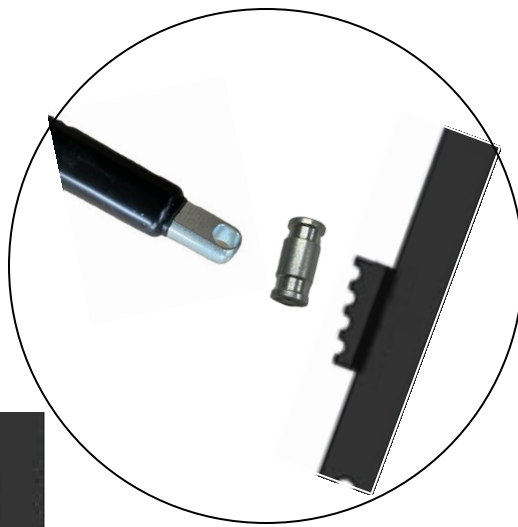
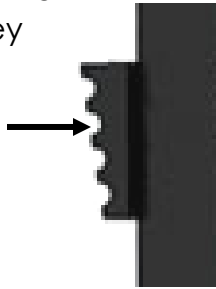
**17****CONNECT THE ARM TO THE DESK**

Raise and LOCK the bed in the UP or CLOSED position. Hold the desk wing and pull the lever arm down and around the bearer post, then release to connect gently with the bearer. You will be compressing the piston as you pull the arm down so it will require force.

Verify that the desk is sitting fully up the side panel. If it is not, slightly loosen the bearer bolts allowing it to do so, then retighten securely.

Apply screws to each of the three flange holes of the bearer fittings on each end of the desk. One lever arm at a time may be released for screw access.

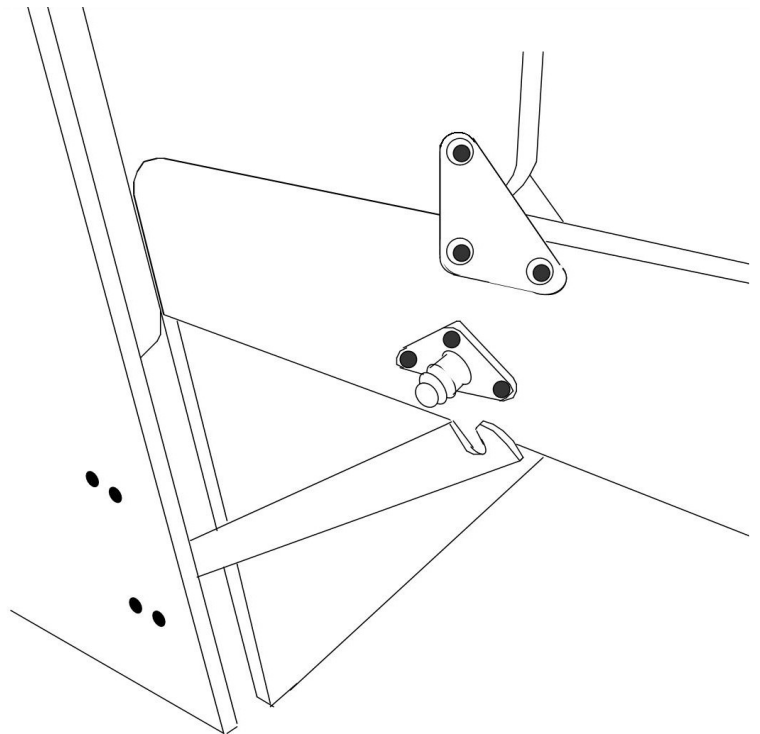
**18****ATTACH HANDLES**

In the center of your bed are 4 holes to secure the decorative handles with the screws and washers provided.

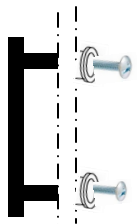
**INSTALL THE CARDBOARD LINER**

Inside the mattress cavity are cross ribs that allow air to circulate around your mattress to prevent mold and mildew. Lay the cardboard liner over the ribs and screw in down in place using wood screws.

19**INSERT MATTRESS**

Strap and buckle your mattress into the mattress tray and tuck excess strapping under one side.





DESK BED OPERATION

BEFORE OPERATING

BED MUST BE SECURELY ATTACHED INTO 3 WOOD STUDS AT THE TOP AND THE MATTRESS MUST BE SECURELY BUCKLED INTO THE BED TRAY. PILLOWS MUST BE REMOVED.

CLEAR AWAY ITEMS ON THE FLOOR UNDER THE DESKTOP. REMOVE FROM THE DESK ITEMS TALLER THAN 14" ON THE VERTICAL MODEL AND 16" ON THE HORIZONTAL MODEL

UNLOCK THE BED

ON BOTH SIDES OF THE DESK AT THE TOP OF THE DESK ENDS THERE ARE PLUNGER LOCKS. PULL THE LOCKS TO RELEASE THE BED.

TO OPEN THE BED

STANDING IN FRONT OF THE BED, PULL ON THE HANDLE WHILE PUSHING DOWN ON THE DESKTOP. ONCE THE BED STARTS TO OPEN THE PISTONS WILL ASSIST IN LOWERING THE BED.

CARE

To care for your furniture-just wipe with a soft damp cloth and then dry the surface immediately. All wood is susceptible to scratches and dings so use coasters and pads to protect your furniture.

DO NOT SIT OR STAND ON DESK **DESK DOES NOT FOLD UP**

LIFTING UP THE DESKTOP AND SITTING OR STANDING ON THE DESKTOP WILL BEND THE MECHANISM AND BREAK THE BED.

THIS IS NOT COVERED UNDER THE WARRANTY.



REMOVE ITEMS UNDER DESKTOP BEFORE YOU LOWER THE BED

ITEMS UNDER THE DESKTOP WILL BE DAMAGED WHEN YOU LOWER THE BED AND YOU WILL BEND THE MECHANISM MAKING THE BED INOPERABLE.

THIS IS NOT COVERED UNDER THE WARRANTY.



REMOVE ITEMS OVER 14" FROM DESK

ITEMS TALLER THAN 14" ON THE VERTICAL MODEL AND 16" ON THE HORIZONTAL MODEL WILL BE DAMAGED WHEN YOU LOWER THE BED. LEAVING TALL ITEMS ON THE DESK

CAN BEND THE MECHANISM MAKING THE BED INOPERABLE.

NOT COVERED UNDER THE WARRANTY.

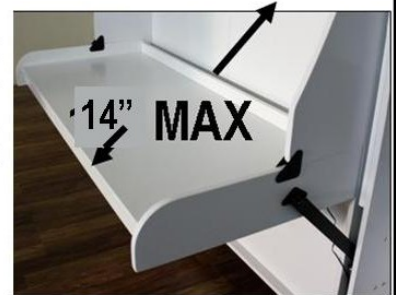

FAILURE TO FOLLOW THESE DIRECTIONS WILL VOID THE WARRANTY

WARNING! ALL PISTONS CONTAIN STORED ENERGY. FAILURE TO FOLLOW THESE INSTRUCTIONS COULD RESULT IN DAMAGE TO THE PRODUCT, PERSONAL INJURY OR DEATH.. PLEASE CALL 916-607-7728 WITH ANY QUESTIONS.